

MAJI KILA SIKU

Kenya's No.1 Water Tank

30 Years' Expected
Lifespan Outdoors

Kenya's No.1
Water Tank



Available in 100 Litres - 24000 Litres

YOU CAN PURCHASE ALL OUR PRODUCTS AT
EQUITY BANK AGENTS
WATER ACCESS & STORAGE PRODUCTS



Gutters



Drums



Underground Tanks

An ASTI Group Company

AST KENTAINERS

innovative solutions • for lasting prosperity

In Partnership With



OUR PRODUCTS

QDesk - Student Desks



- Maximizes student's comfort and safety and enables real learning to happen
- Award winning design
- No edges or sharp corners
- Innovative, comfortable, durable and affordable school desk, for all schools and universities

Ksh. 7,500

Cattle Drinkin Trough with Ball Valve



- Made from food contact grade U.V stabilized polyethylene U.V stabilized polyethylene
- 30 Years' expected lifespan
- Tough & Long lasting

Ksh. 16,500

WonderLoo



- Toilet pedestal for fully or partially ecological sanitation
- Ideal for the elderly & handicapped
- Innovative, comfortable, durable and affordable

Cattle Drinking & Feeding Trough



- Made from food contact grade U.V stabilized polyethylene U.V stabilized polyethylene
- 30 Years' expected lifespan
- Tough & Long lasting

Ksh. 8,500

DRUM



- Tough
- Easy to clean
- Long lasting

200ltr
Ksh.1,900

100ltr
Ksh.1,300

Hermetic Grain Silo



- For 4 x 90 kg bags of dry grains for smallholders
- Store grain longer safely
- Reduce post-harvest losses
- Earn more by selling grain when prices improve
- 30 years' expected lifespan indoors.

Ksh. 8,000

Blueflame Bioslurry Gas

Ksh.186,521



Features

- 30 years' expected lifespan outdoors
- Compact and Portable
- No pit required
- Installed above ground in 2 hours
- Easy to operate and maintain
- Supplied with a double burner biogas stove with 15 meters gas pipe
- It generates bioslurry, an organic fertilizer which is very effective for its higher nutrients value.
(For more details, visit on our website download brochure on Blueflame bioslurry Gaz)

K-POT



k-POT 30Ltr
Ksh.1,200

k-POT 60Ltr
Ksh.1,900



INDUSTRIAL PRODUCTS

INMOTION

We offer a comprehensive range of products that are designed to meet the specific needs of our customers. Our products are made from high quality materials and are subject to rigorous quality control procedures. This ensures that our products are safe to use and meet the highest standards of performance.



QDESK



ROAD BARRIER



ROAD BARRIER

Features

- Made from 100% Food grade-virgin material
- Durable
- Available in different colours
- Supplied with basin, tap, 20L
- collection buckets & Metal stand

Applications

- Food processing,
- Pharmaceuticals,
- Cosmetics,
- Chemical manufacturing etc.

An ASTi Group Company

AST KENTAINERS

innovative solutions • for lasting prosperity

KENTAINERS LIMITED

Nairobi Gate Industrial Park,

10902/19, Northland Area,

Eastern Bypass,

P.O Box 42168-00100, Nairobi, Kenya,

Tel: +254 20 251 9098 / 2519099,

0722 206 378 / 0730 832 000

www.kentainers.co.ke



GUTTERS AND ACCESSORIES

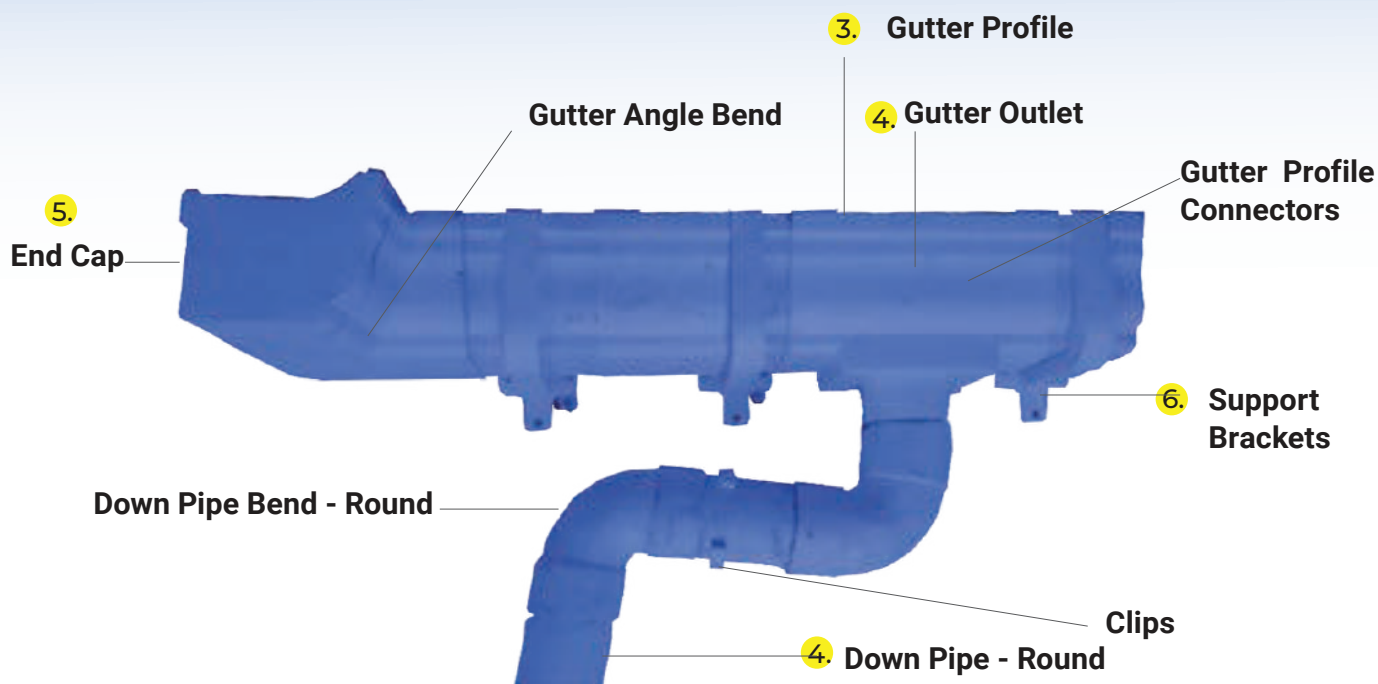

Features

- Made from food grade U.V stabilized polyethylene
- Long lasting
- cost effective
- Strong
- Light weigh

B	Lifeline Gutters	PRICE INC VAT K.Shs
1	Gutter Profile 6 metre long	2,277
2	Gutter Outlet	208
3	Gutter Angle Bend (left and right)	344
4	Gutter Profile Connectors	84
5	End Caps (left and right)	116
6	Support Brackets	71
7	Down Pipe - Round	600
8	Down Pipe Bend – Round	350
9	Diverter	1,000
10	Down Pipe Clips	120
11	Lockable Tap 1 inch	850

Application

- Schools,Clinic, IDP, Refugees camps
- Institutions
- Farms, Homes and Construction Sites

